

ZA-0300-1-ACB



Despite its low current consumption, the ZA-0300-1-ACB delivers a respectable 300 N and features ACB technology with all the advantages of this bus technology.

Performance features

- + Can be used for openings for smoke exhaust; D+H Euro SHEV in accordance with EN 12101-2; and for daily ventilation
- + With BSY+ motor and synchronised electronics controlled via microprocessor
- + High-speed function (HS) for especially fast opening windows in case of fire (SHEV) (optionally available)
- + Option of up to 8 drives in one synchronous group
- + Option of cable infeed above and below
- + Drive unit can be changed from left to right
- + Programmable drive functions and different drive parameters
- + Running speed in CLOSED direction decreases to 5 mm/s (passive closing edge protection)
- + Time-controlled reversing when an obstacle is detected in the CLOSED direction (active closing edge protection)
- + Integrated ACB (Advanced Communication Bus) bus interface with Modbus RTU protocol
- + The drive is integrated directly via open bus communication through the ACB (Advanced Communication Bus), e.g. in a building management system

Approvals / Certificates

Find out about permission details from your D+H Partner.



Technical data

ZA-0300-1-ACB

| | |
|-------------------------------|---------------------------------|
| Supply | 24 V DC / $\pm 15\%$ / 0.5 A |
| Duty cycle | 30 % (ON: 3 min. / OFF: 7 min.) |
| Force of pressure | 300 N |
| Tensile force | 300 N |
| Nominal locking force ** | Max. 1400 N (1100 N ***) |
| Service life | 20000 double strokes * |
| Stroke | Configurable |
| OPEN running speed | 7 mm/s |
| OPEN running speed - SHEV | 7 mm/s |
| CLOSED running speed | 7 mm/s |
| Type of protection | IP 65 |
| Emission sound pressure level | LpA \leq 51 dB(A) |
| Temperature range | -15 °C (-5 °C ***) ... +75 °C |
| Fire resistance | B300 (30 min / 300 °C) |
| Housing | Aluminium / Polycarbonate |
| Surface | Powder-coated |
| Colour | White aluminium (~ RAL 9006) |
| Connection | 2.5 m silicone cable |
| Art. No. | 27.011.00 |

* For vertical use, please consult with D+H Sales!

** Depending on the mounting, *** in accordance with VdS 2580

Dimensions

All specifications in mm

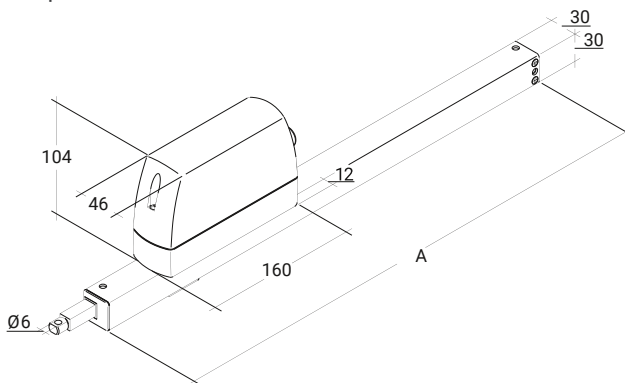

Pressure load diagram

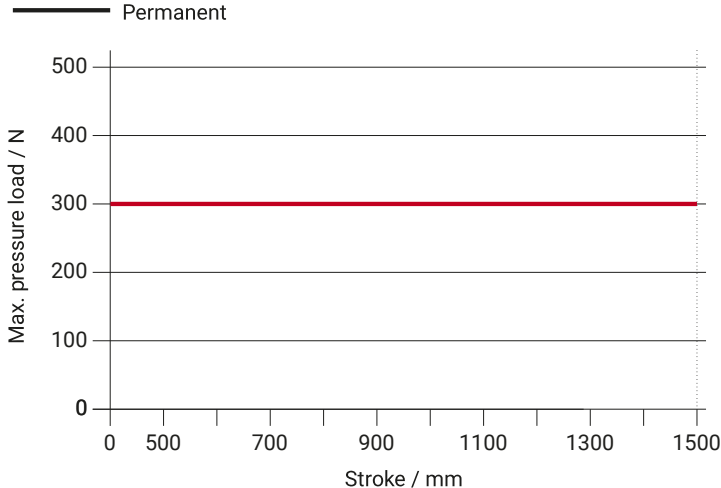

Possible applications

- + Mounted installation
- + Frame mounting
- + Sash mounting
- + Installation opposite the hinge
- + Side installation
- + Application force
- + Application tension
- + Trapezoidal application

